

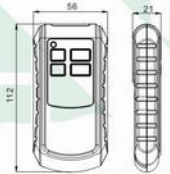

Digital Crane Scale

XZ Series

Unit:mm

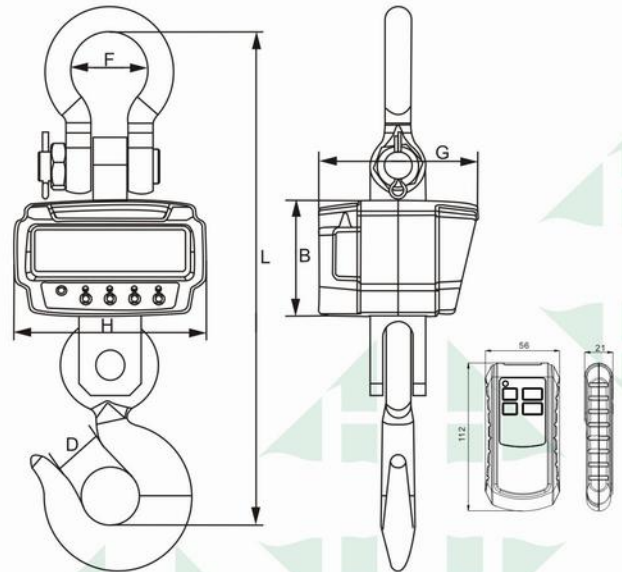

Remote Control

Palm Indicator Selectable



Built-in beeper



EU standard



battery



Lb/kg/kN selectable



IR



PDA

Features

- Aluminum diecasting alloy housing with strength and pleasant appearance
- Super bright 5 digit red LED display with 40mm height
- Infrared control with Peak Hold, Tare, Zero, Total function
- Optimized design, wireless palm indicator optional after upgrading

Technical Parameter

- Executive Standard OIML R76
- Accuracy III
- Time to Stable Reading ≤8s
- Maximum Safe Load 125%F.S.
- Limited Overload 400%F.S.
- Overload Alarm 100%F.S.+9e
- Surrounding -20℃ ~ 60℃
- Operating Temperature -10℃ ~ 40℃

Max Capacity	Division	B	H	L	F	G	D
1000kg	0.5/0.2kg	119	198	420	76	163	40
2000kg	1/0.5kg	119	198	420	76	163	50
3000kg	1/0.5kg	119	198	462	76	163	50
5000kg	2/1kg	119	198	511	80	163	52
10000kg	5/2kg	134	206	589	90	180	52
15000kg	5/2kg	134	206	727	135	180	60